

# ETSFG

## Experimental and Theoretical Spectroscopy of Functionalized Graphene

Projet blanc international ANR-FWF (Austrian Science Fund)

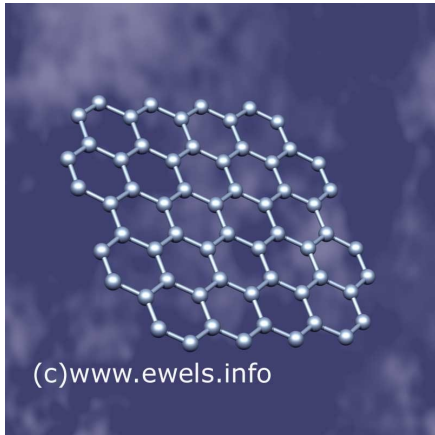

Ludger Wirtz

*IEMN*

*(Inst. for Electronics, Microelectronics,  
and Nanotechnology) Lille, France*

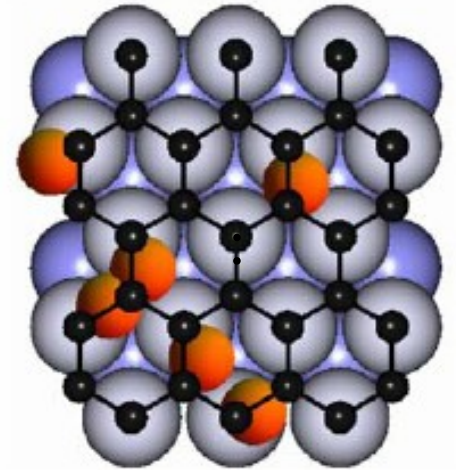

Project Partner: **Thomas Pichler** (Experiment)  
*Electronic Properties of Materials*  
*Faculty of Physics, University of Vienna, Austria*



# ETSFG

## Experimental and Theoretical Spectroscopy of Functionalized Graphene

### Motivation of the project:

three growth methods of graphene

- 1.) Exfoliation
- 2.) Epitaxial growth on SiC
- 3.) Chemical Vapor deposition on metallic substrates  
Gaining rapidly importance since 2009

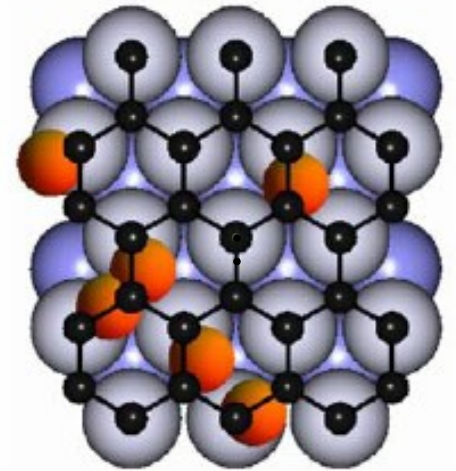

To isolate the graphene, one needs to understand the interaction with the substrate => spectroscopy

- **band structure** on different substrates  
(e.g., to explain ARPES measurements)
- **electronic excitations** (always involved in light-matter interaction, but difficult to calculate due to **correlation effects**)
- **phonon dispersions** (to explain Raman and HREELS measurements)

# ETSFG

## Experimental and Theoretical Spectroscopy of Functionalized Graphene

### Graphene (and related hexagonal materials):

- graphene
- hexagonal boron nitride
- $\text{MoS}_2$

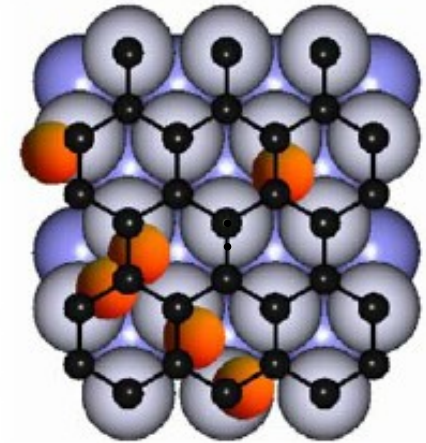

### Functionalized graphene:

- graphene in interaction with a substrate (metallic or insulating)
- graphite intercalation compounds
- graphene with attached atoms/molecules (not regarded in this project)
- graphene with defects

# Electronic properties of different hexagonal materials

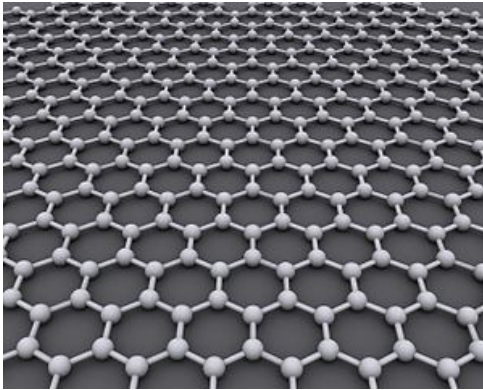

Graphene

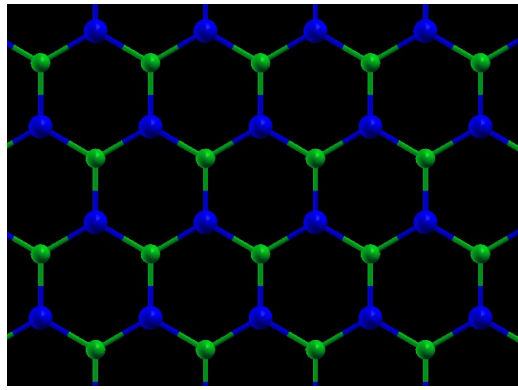

Hexagonal boron nitride

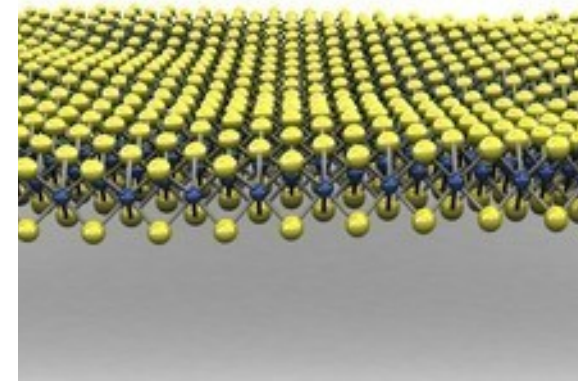

Molybdenum disulfide

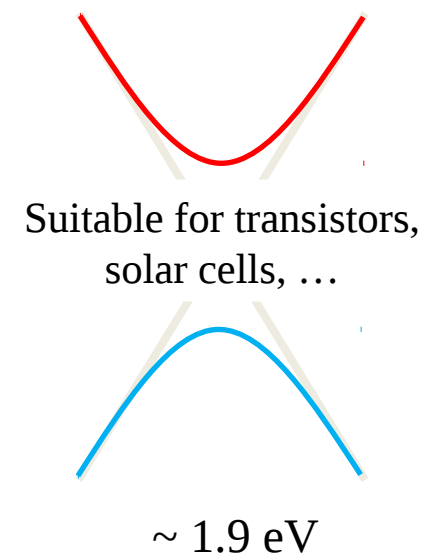
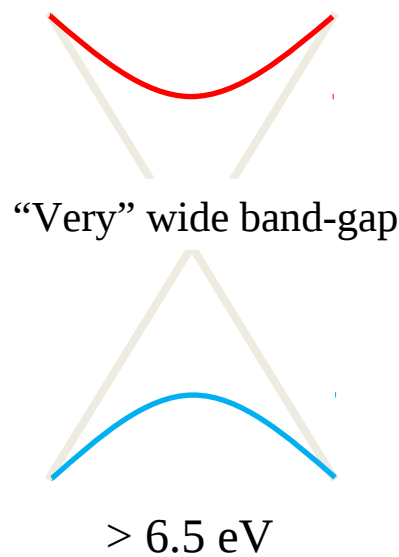
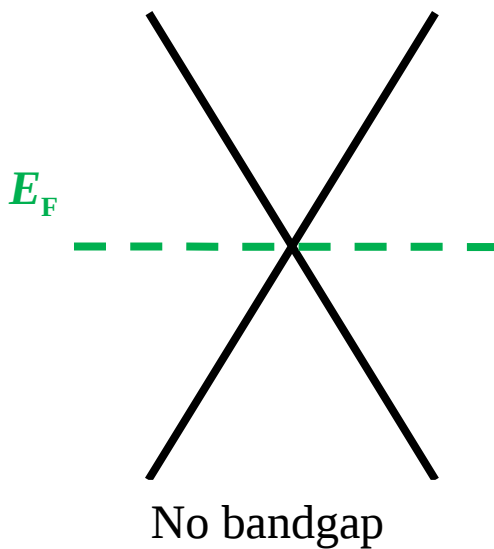

# Outline

- 1.) Phonons of graphene
  - a.) Graphene on a metallic substrate
  - b.) Graphene on an insulating (dielectric) substrate
  - c.) graphite intercalation compounds
  
- 2.) Optical excitations of MoS<sub>2</sub>
  
- 3.) Ongoing work/perspektives (interaction of graphene with nanocrystals)

# Background: need to understand the Highest optical phonon branch of graphite

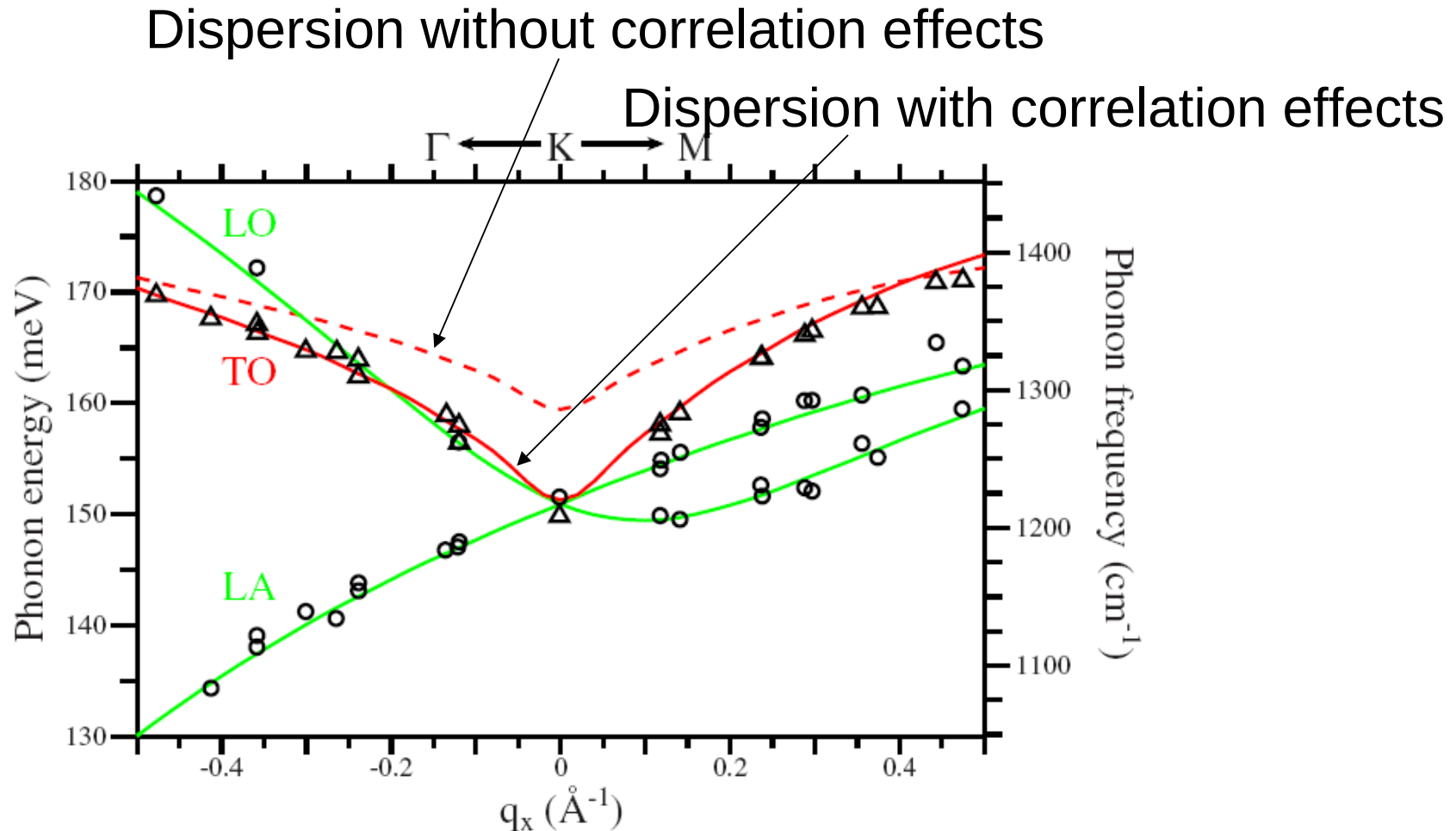

Measurements by inelastic x-ray diffraction (ESRF Grenoble) in comparison to ab-initio calculations (with DFT and beyond)

A. Grüneis, J. Serrano, A. Bosak, M. Lazzeri, S.L. Molodtsov, L. Wirtz, C. Attaccalite, M. Krisch, A. Rubio, F. Mauri, T. Pichler, PRB **80**, 085423 (2009). ANR JCJC CPONN (2006-2008)

# Calculation method : beyond DFT

Many-body perturbation theory

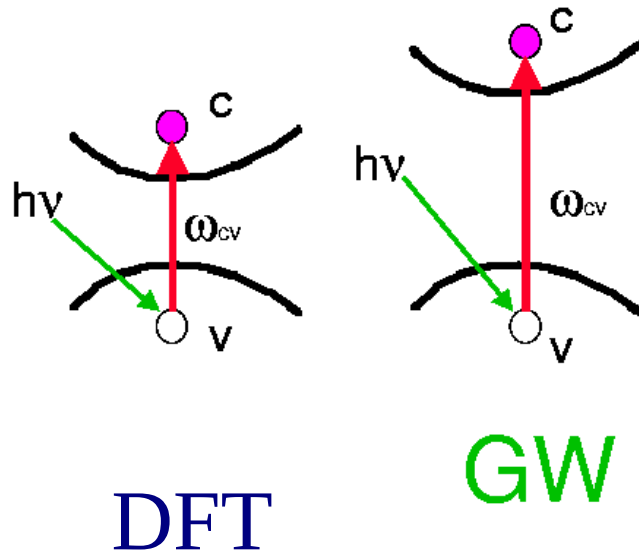

What about the screening by the dielectric substrate?

- 1.) DFT : underestimation of the band-gap
- 2.) GW-approximation (including e.-e. interaction) : “opening” of the band gap

$$\left[ -\frac{\nabla^2}{2} + V_{ext}(\mathbf{r}) + V_{Hartree}(\mathbf{r}) \right] \psi_{n\mathbf{k}}^{qp}(\mathbf{r}) + \int d^3\mathbf{r}' \Sigma(\mathbf{r}, \mathbf{r}'; E_{n\mathbf{k}}^{qp}) \psi_{n\mathbf{k}}^{qp}(\mathbf{r}') = E_{n\mathbf{k}}^{qp} \psi_{n\mathbf{k}}^{qp}$$

Self energy:  $\Sigma = iGW$  — screened Coulomb potential

# ARPES: $\pi$ bands of graphite

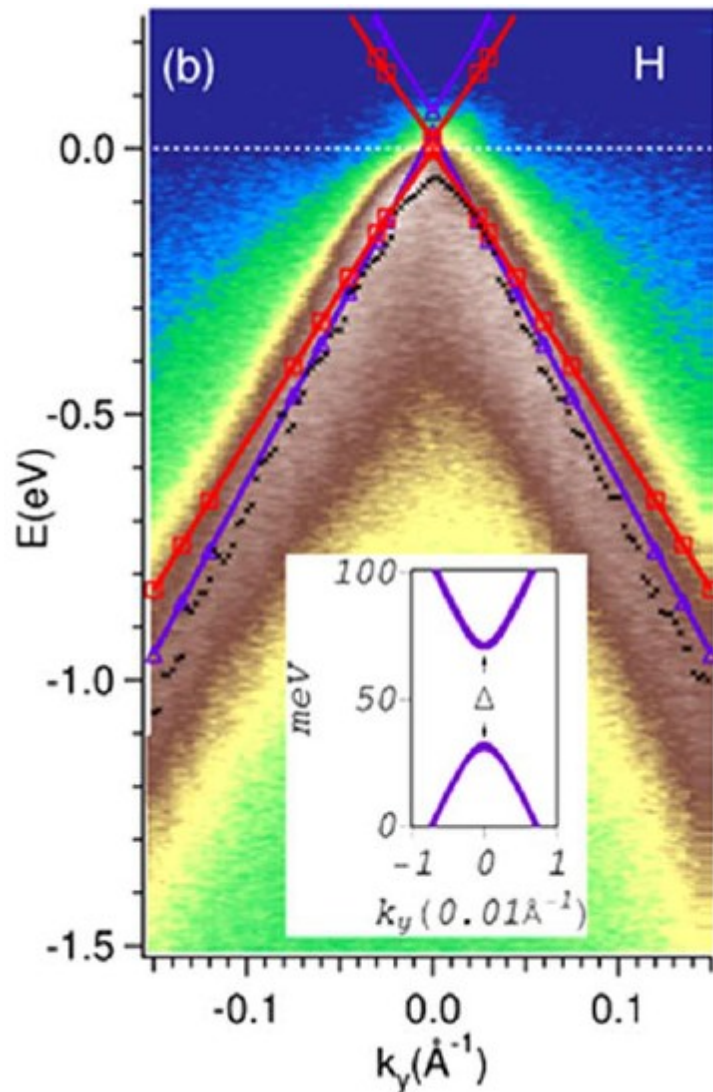

red: LDA

$$v_F = 0.87 \cdot 10^6 \text{ m/s}$$

violet: GW

$$v_F = 1.02 \cdot 10^6 \text{ m/s}$$

color plot and  
black circles:  
ARPES

$$v_F = 1.05 \pm 0.1 \cdot 10^6 \text{ m/s}$$

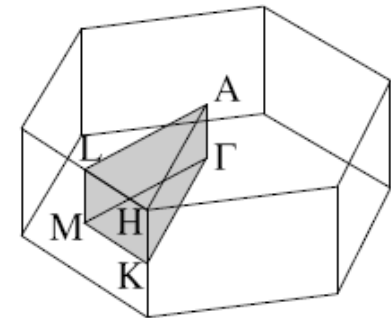

GW reproduces the “Fermi velocity” (slope of  $\pi$  bands)

A. Grüneis, C. Attaccalite, T. Pichler, V. Zabolotnyy, H. Shiozawa, S. Molodtsov, D. Inosov, A. Koitzsch, S.V. Borisenko, M. Knupfer, J. Schiessling, R. Follath, P. Rudolf, L. Wirtz, and A. Rubio, Phys. Rev. Lett. (2008). ANR JCJC CPONN (2006-2008)

# Raman spectroscopy of double-layer graphene

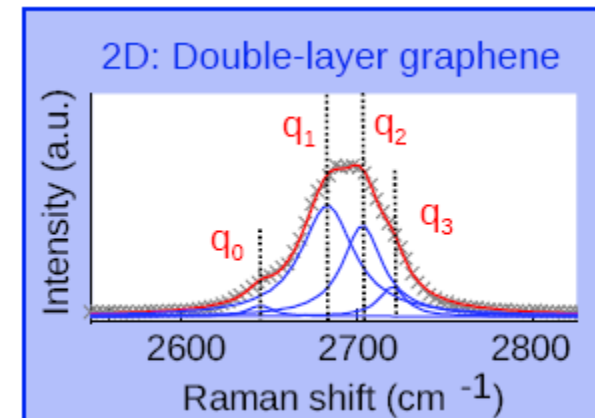
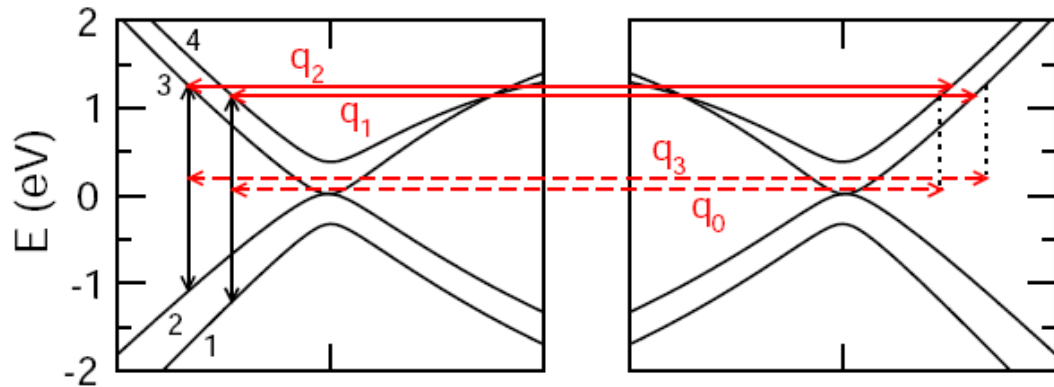
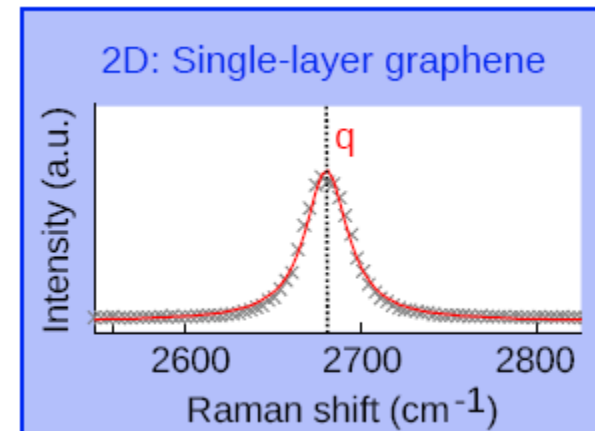
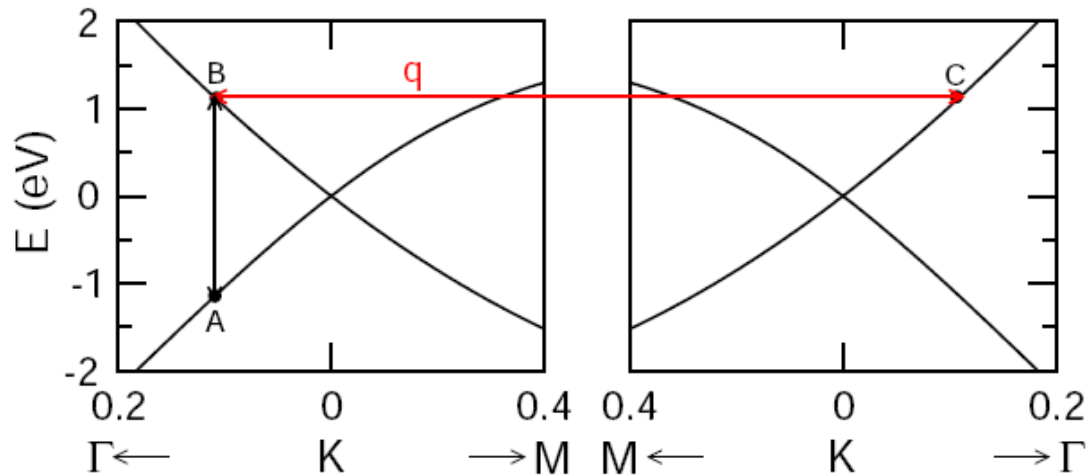

In the bi-layer: splitting of the 2D peak  
well explained by the double-resonance Raman model

A. C. Ferrari et al, PRL **97**, 187405 (2006).

D. Graf, F. Molitor, K. Ensslin, C. Stampfer, A. Jungen, C. Hierold, L. Wirtz,  
Nano Lett. **7**, 238 (2007).

ANR JCJC CPONN (2006-2008)

# Graphene on metallic substrates: Elimination of the Kohn anomaly for graphene adsorbed on Ni(111)

Graphene@Ni(111) :  
hybridization of  $p_z$  orbitals  
of graphene with the d  
orbitals of nickel

=> Elimination of the  
Kohn anomaly

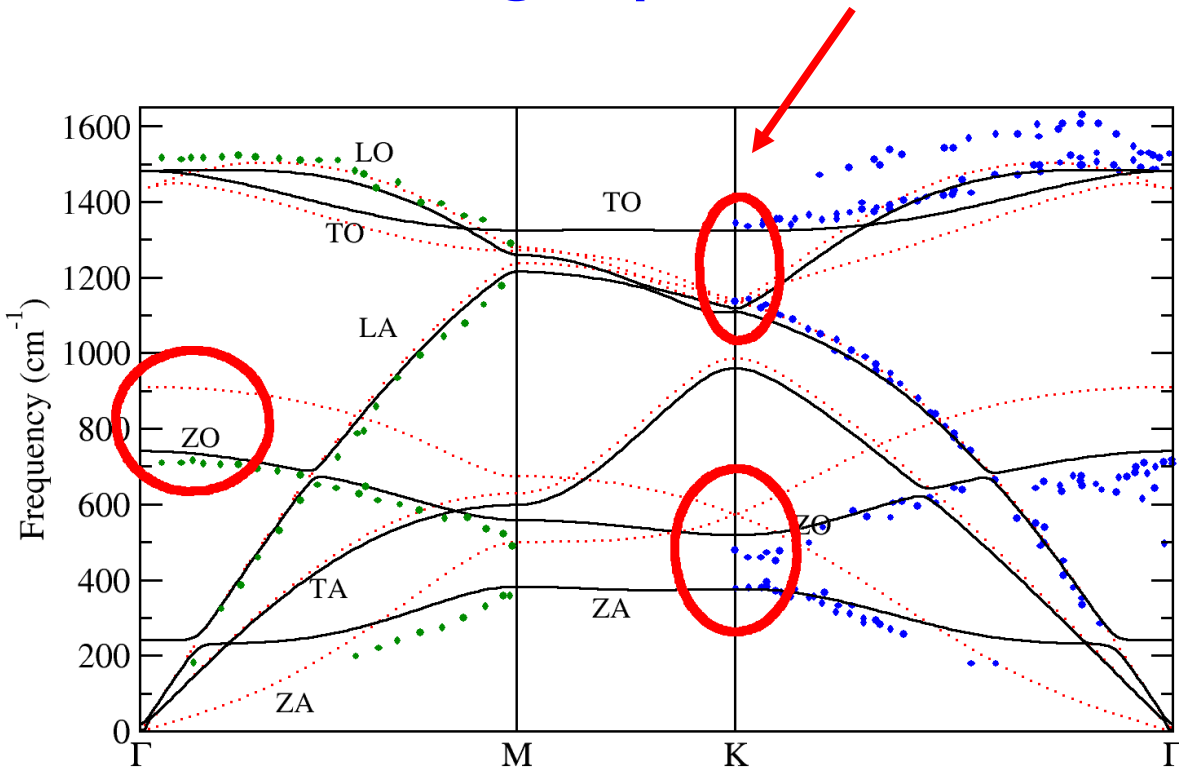

green points : Aizawa et al, Surf. Sci. 1990  
blue points : Shikin et al., Surf. Sci. 1999

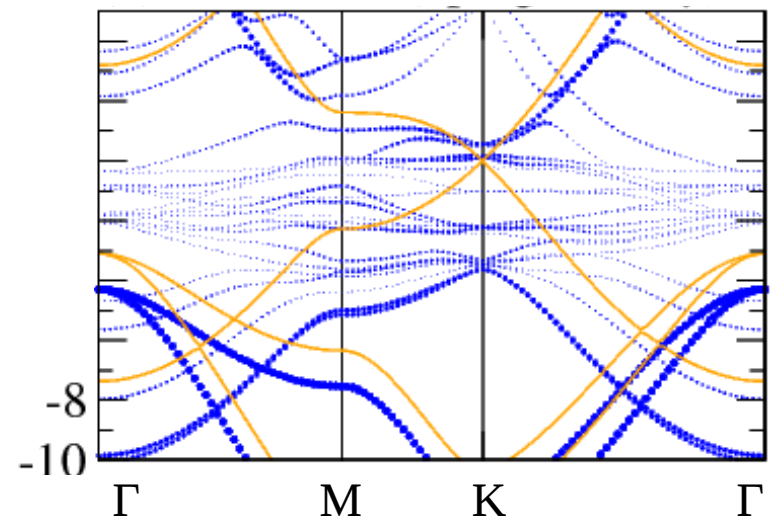

# Kohn Anomaly as a function of binding distance

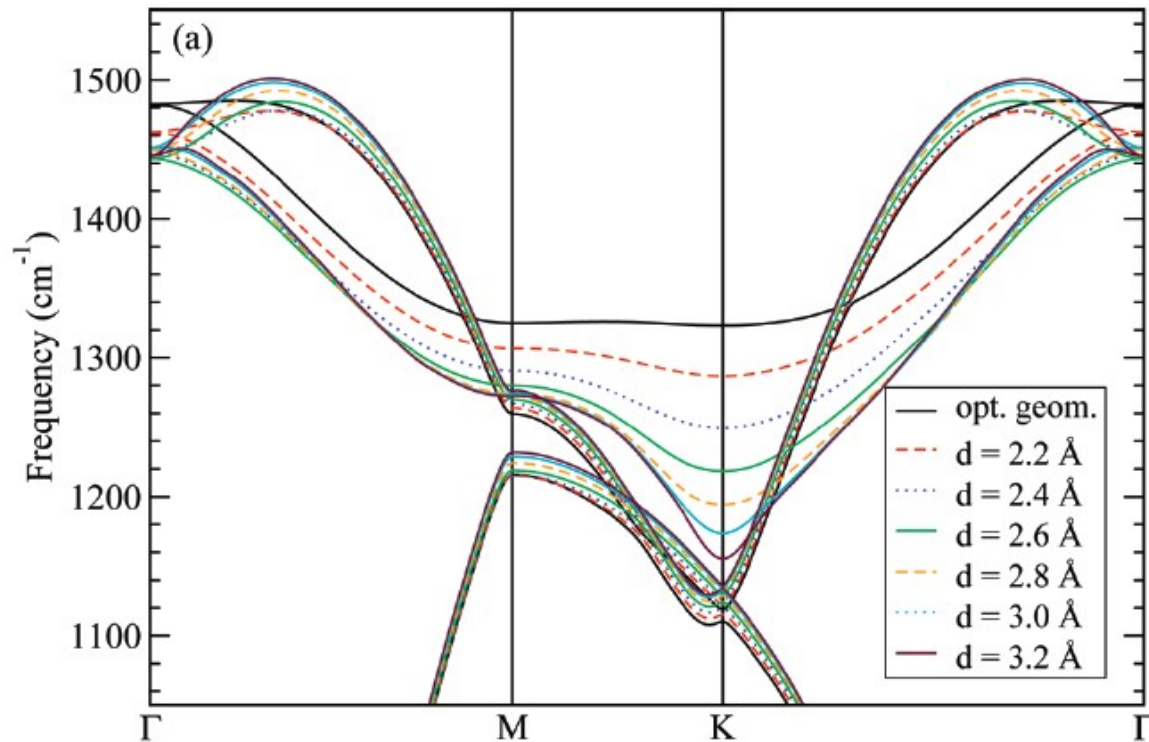

decreasing hybridization  
with increasing distance  
restores the Kohn  
anomalies at K and  $\Gamma$

Comparison with  
experimental dispersion  
gives information  
on absorption strength

electronic structure as function of binding distance

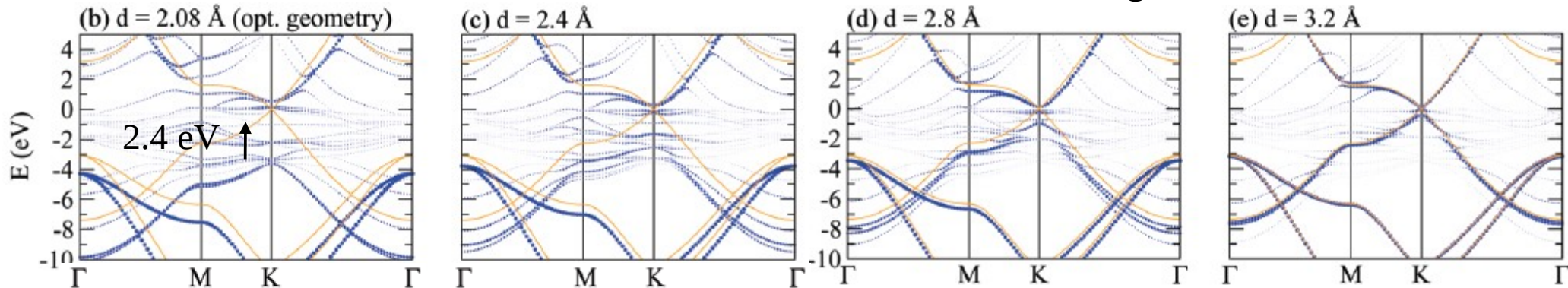

# Some recent Raman data on graphene

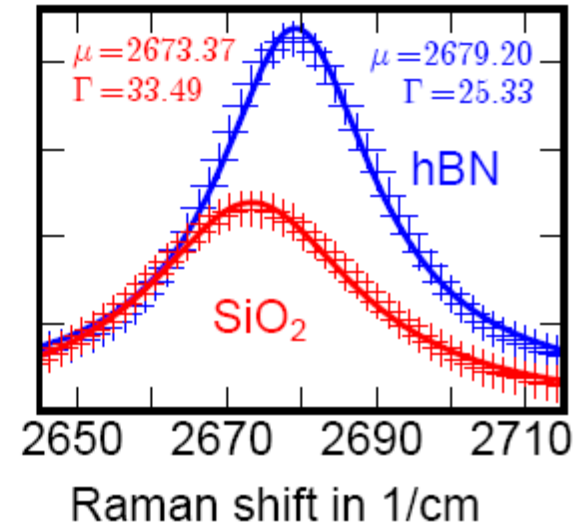
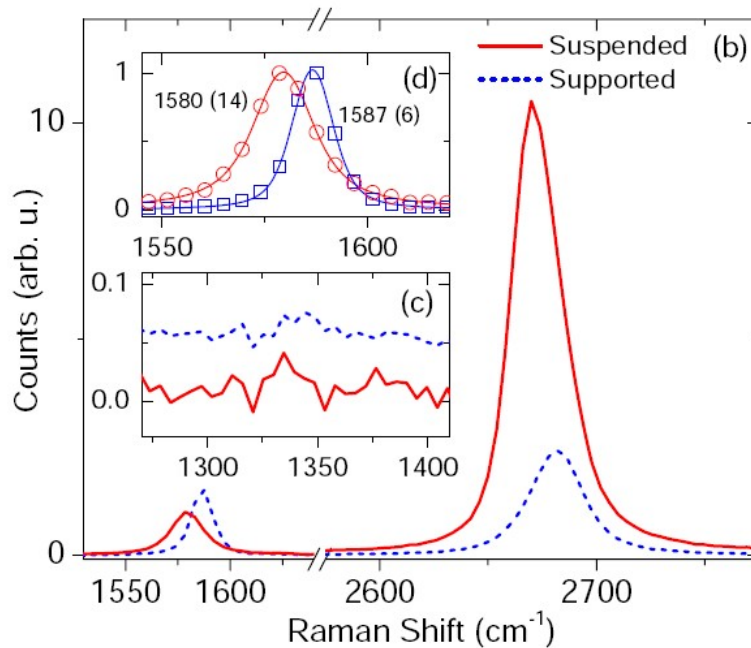

2D-line of suspended graphene **lower** than that of graphene@SiO<sub>2</sub>

2D-line of C@hBN **higher** than that of C@SiO<sub>2</sub>

S. Berciaud, S. Ryu, L.E. Brus, T.F. Heinz, Nano Lett. 9, 346 (2009).

Florian Forster, Christoph Stampfer,

# Comparison of 2D-line on different substrates

suspended graphene



What is the origin of this substrate dependence?

Charge transfer?

# Calculation method : beyond DFT

Many-body perturbation theory

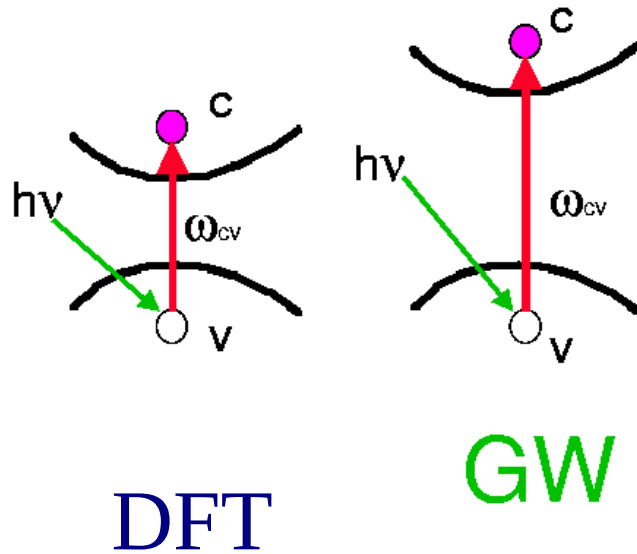

What about the screening by the dielectric substrate?

- 1.) DFT : underestimation of the band-gap
- 2.) GW-approximation (including e.-e. interaction) : “opening” of the band gap

$$\left[ -\frac{\nabla^2}{2} + V_{ext}(\mathbf{r}) + V_{Hartree}(\mathbf{r}) \right] \psi_{n\mathbf{k}}^{qp}(\mathbf{r}) + \int d^3\mathbf{r}' \Sigma(\mathbf{r}, \mathbf{r}'; E_{n\mathbf{k}}^{qp}) \psi_{n\mathbf{k}}^{qp}(\mathbf{r}') = E_{n\mathbf{k}}^{qp} \psi_{n\mathbf{k}}^{qp}$$

Self energy:  $\Sigma = iGW$  — screened Coulomb potential

# Recalculate the e-ph coupling of graphene symmetrically sandwiched between BN layers

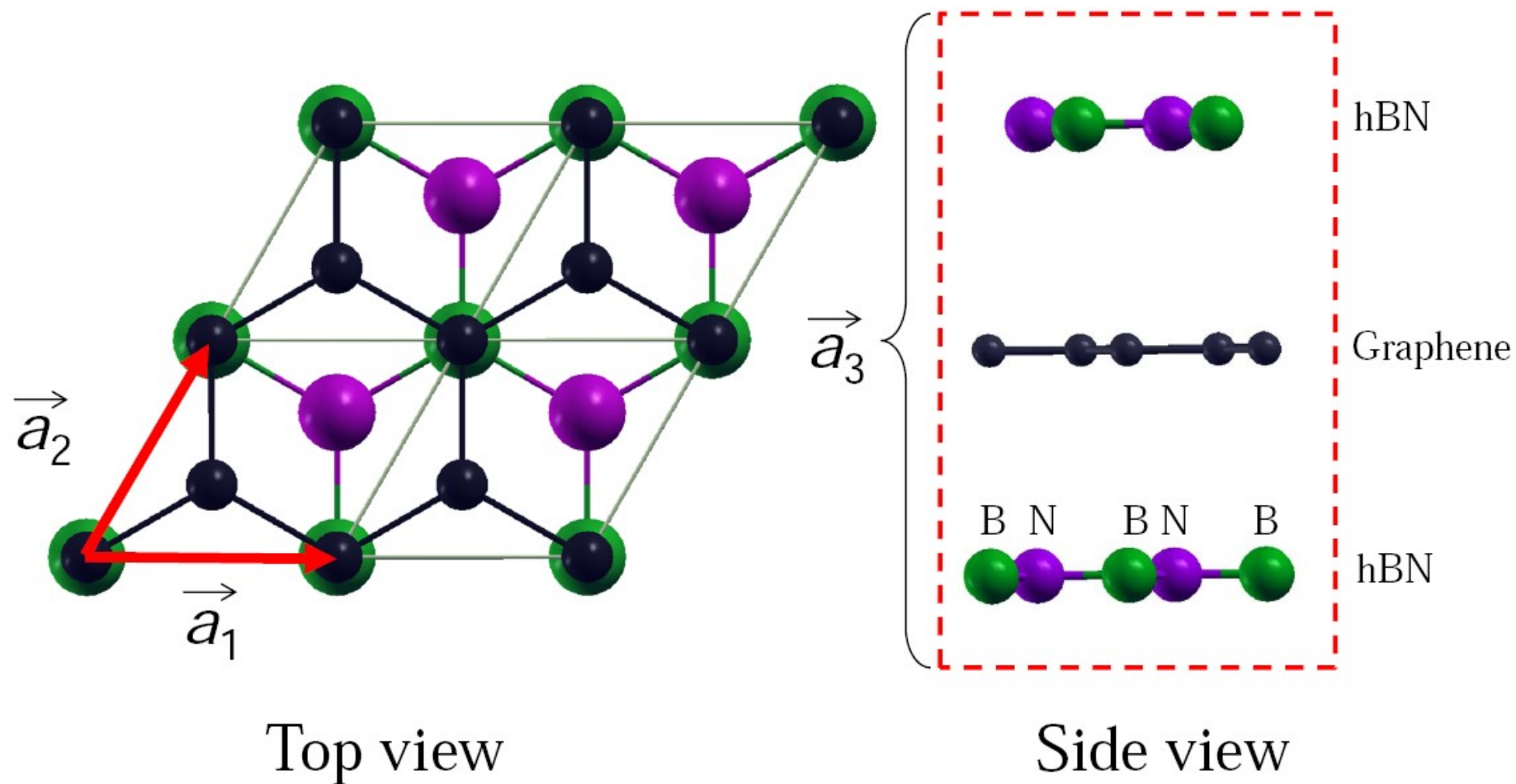

# Screening dependence of Electron phonon coupling

$$\langle D_K^2 \rangle_F \text{ [eV}^2/\text{\AA}^2]$$

	LDA	GW
pure graphene	89.2	207.9
graphene@hBN	86	191.3

The presence of the dielectric substrate reduces the e-ph coupling by 3.5% (LDA), 8% (GW).

- => reduction of the slope of the Kohn-Anomaly by the dielectric substrate
- => increase of the 2D-line phonon frequency

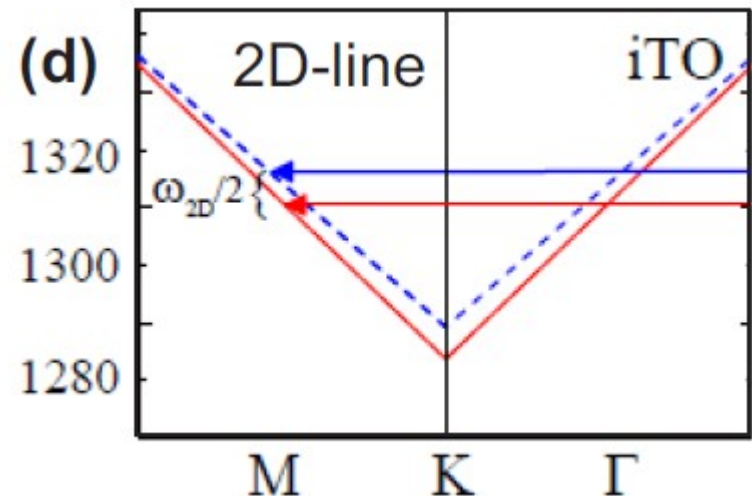

# Raman spectroscopy of graphite intercalation compounds : dependence of 2D-line on staging

Example  $\text{KC}_{36}$ , 3<sup>rd</sup> stage intercalation compound

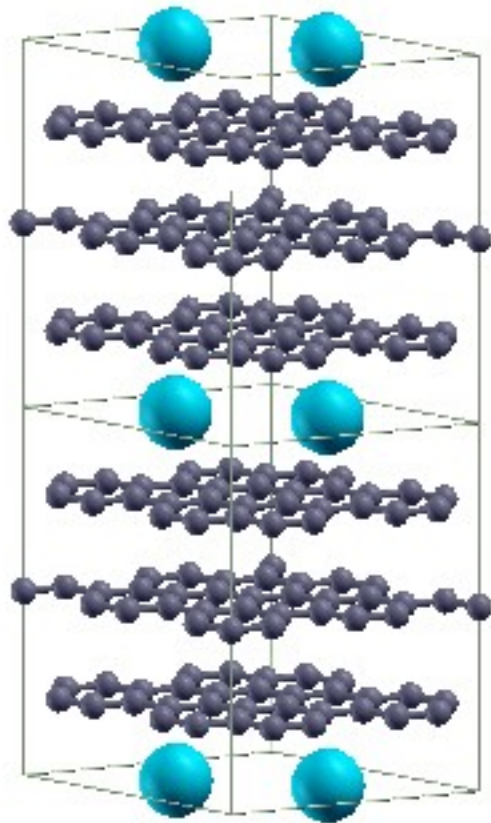

side view

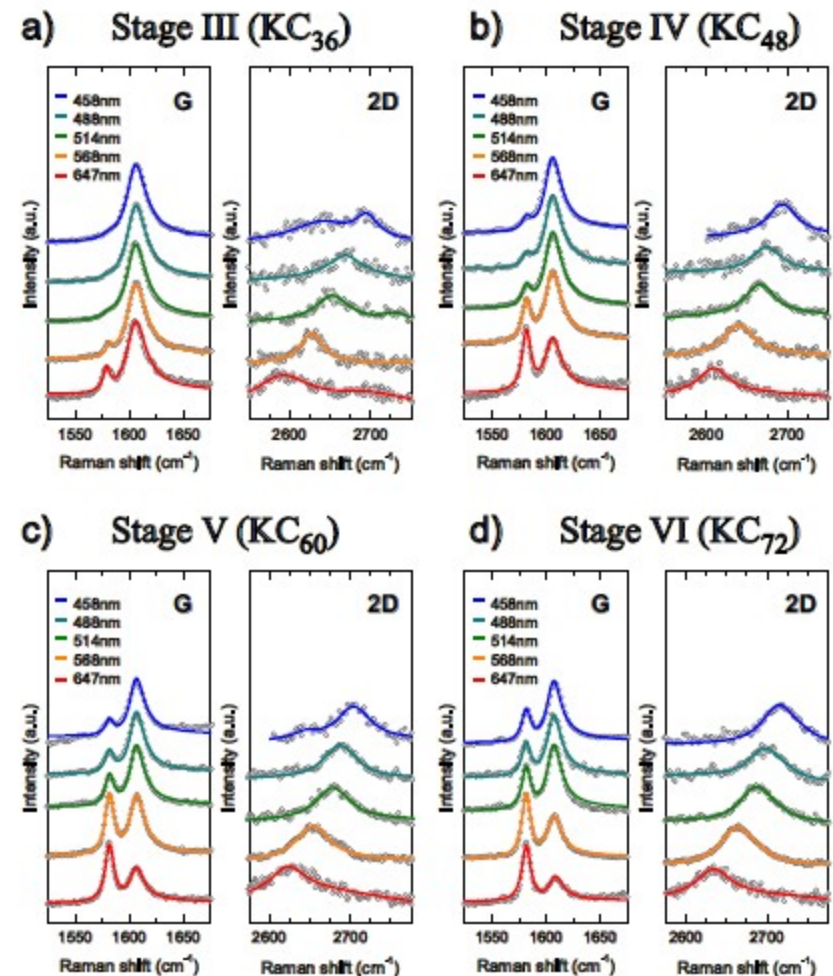

# Raman spectroscopy of K graphite intercalation compounds : dependence of 2D-line on staging

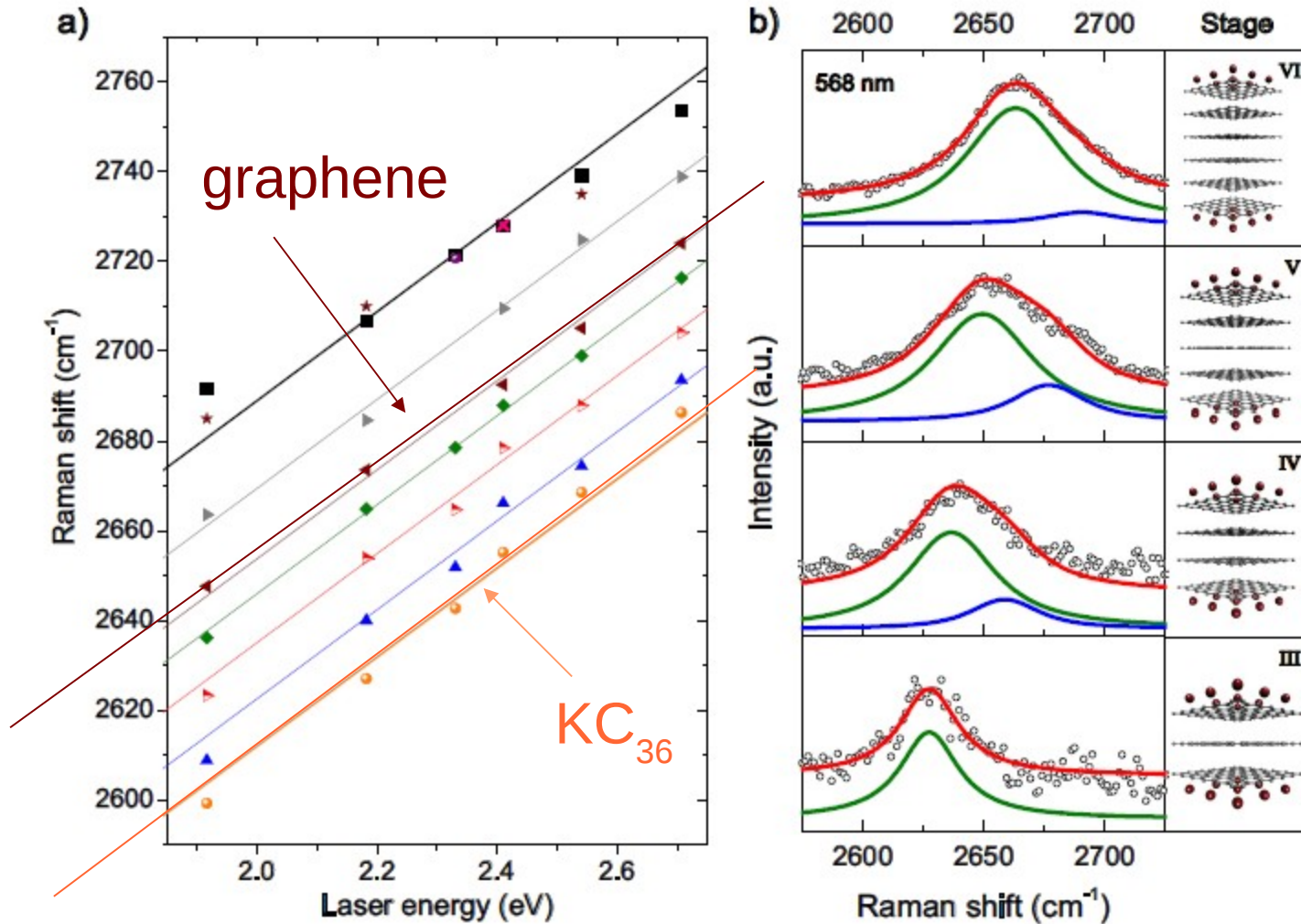

2D-line in KC<sub>36</sub> 40 cm<sup>-1</sup> lower than in single-layer graphene

# Raman spectroscopy of K graphite intercalation compounds : dependence of 2D-line on staging

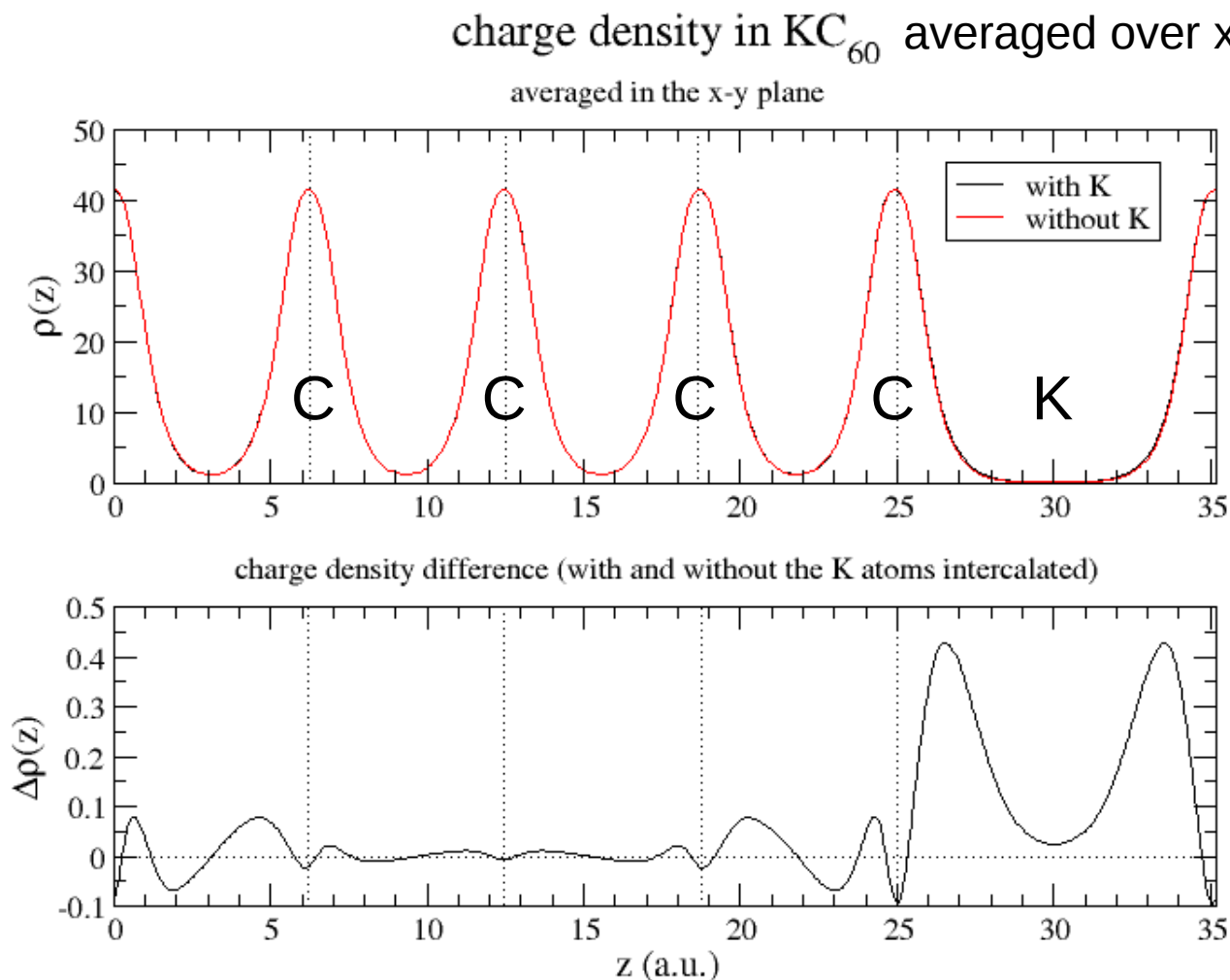

Electron density accumulates between K and outer graphene layer  
inner graphene layers remain (almost) neutral  
 $\Rightarrow$  decoupling of electronic structure of inner and outer layers  
 $\Rightarrow$  Raman 2D-line due to inner layers.

# Raman spectroscopy of K graphite intercalation compounds : dependence of 2D-line on staging

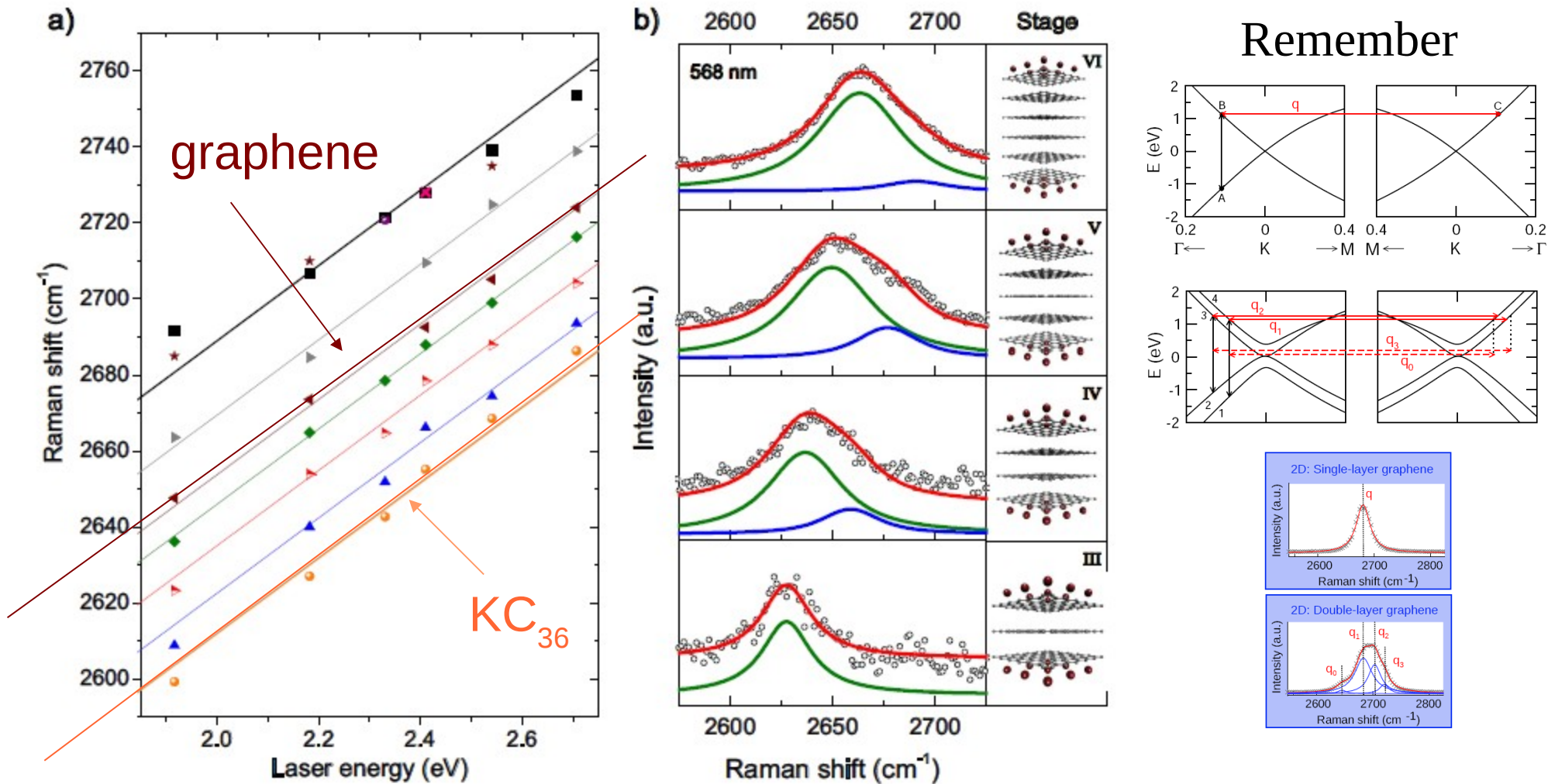

Lowering by  $40 \text{ cm}^{-1}$  due to lattice expansion in GICs

# Excitonic effects in Molybdenum disulfide (single-layer, double-layer, and bulk)

## Band structure

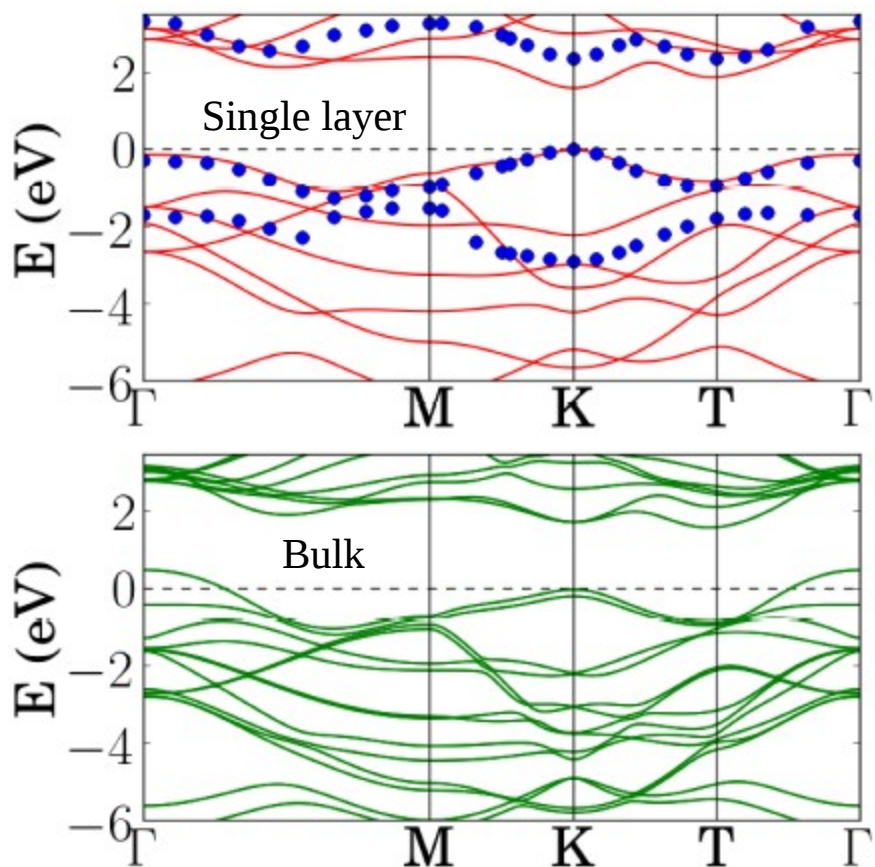

## Absorption spectrum

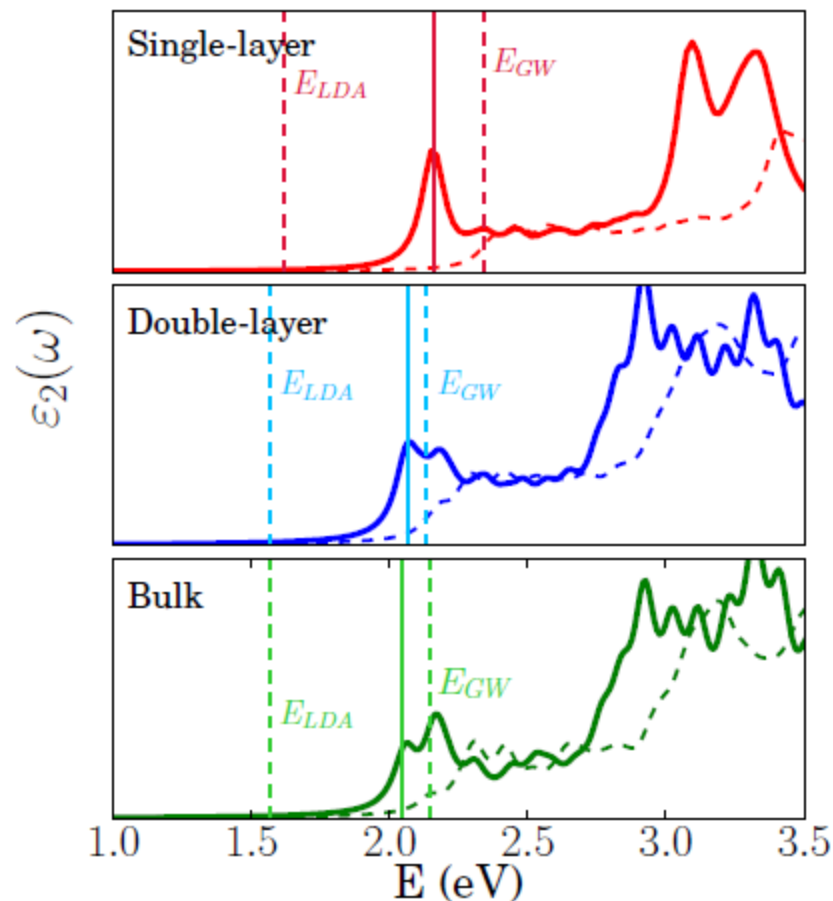

# Excitonic effects in Molybdenum disulfide (single-layer, double-layer, and bulk)

Excitonic wave functions

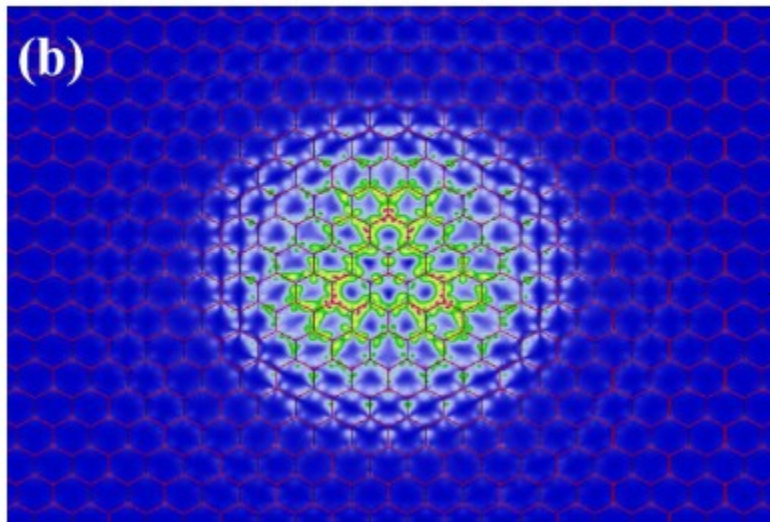
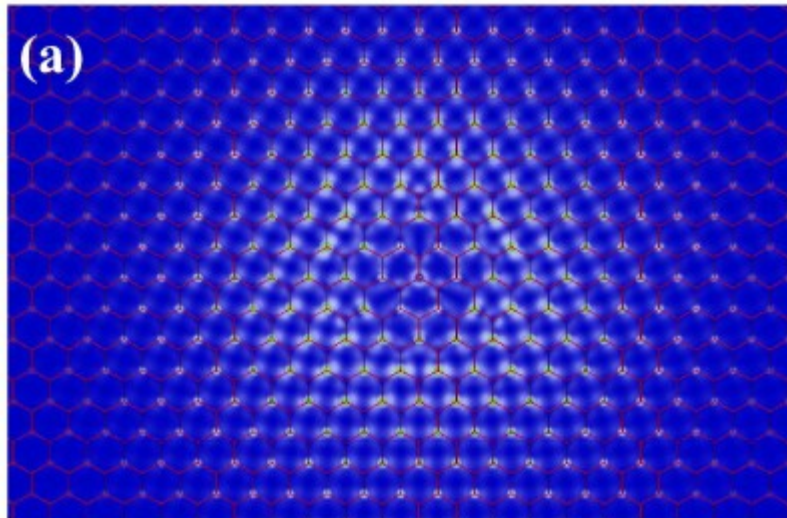

Absorption spectrum

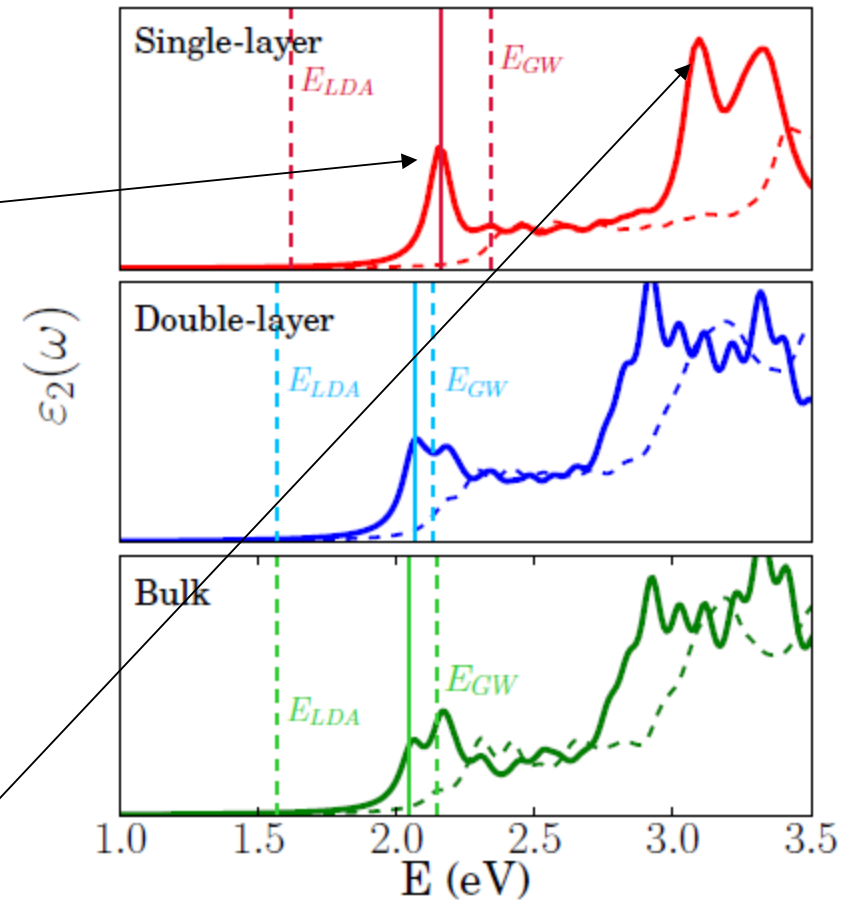

A. Molina-Sánchez and L. Wirtz, in preparation (2012).

# Summary

## Influence of the substrate on the 2D-line of graphene

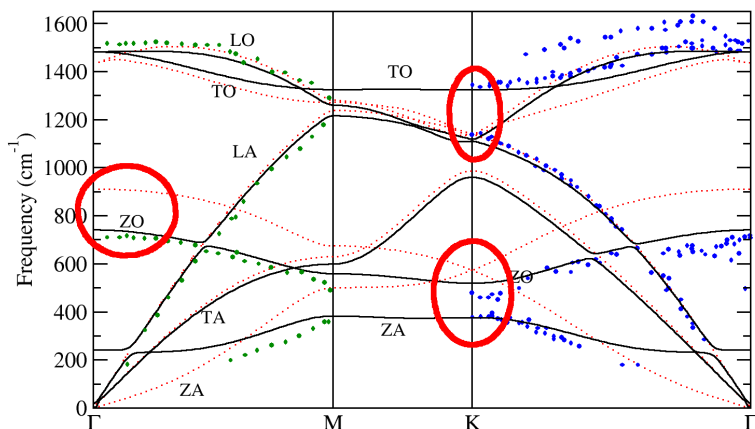

Metallic substrates:  
Band hybridization can lead to elimination of the Kohn-anomaly

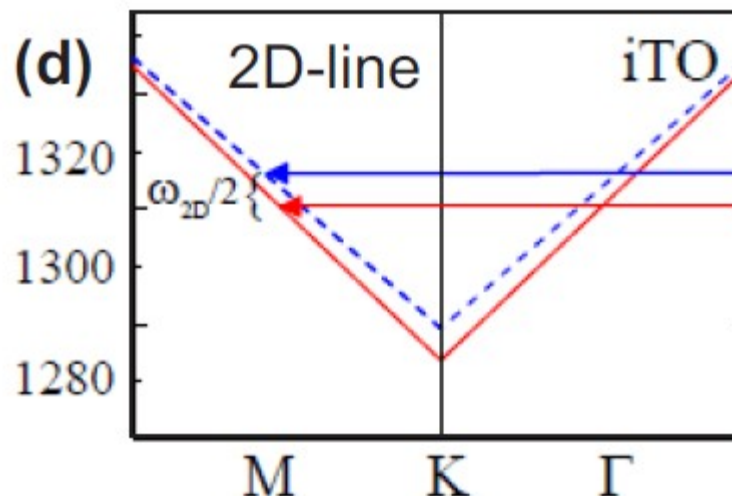

Insulating substrates:  
Screening of the Kohn-Anomaly by the dielectric substrate

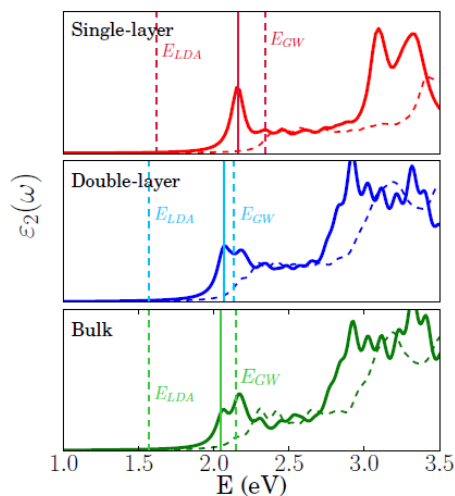

Excitonic effects  
in MoS<sub>2</sub>

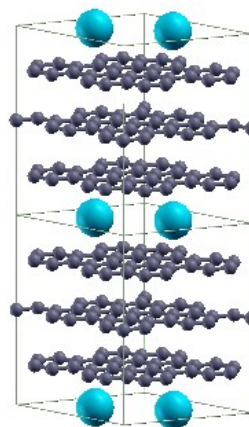

Raman spectroscopy  
of graphite intercalation  
compounds

# ETSFG

## Outlook: Energy transfer between nanocrystals and graphene

Study with tight-binding methods  
(well established for different  
s.c. nanocrystals and graphene)

Fundamental questions:  
distance-dependence of  
energy-transfer via Förster-  
Mechanism.

E. Kalesaki, C. Delerue, L. Wirtz,  
Work in progress

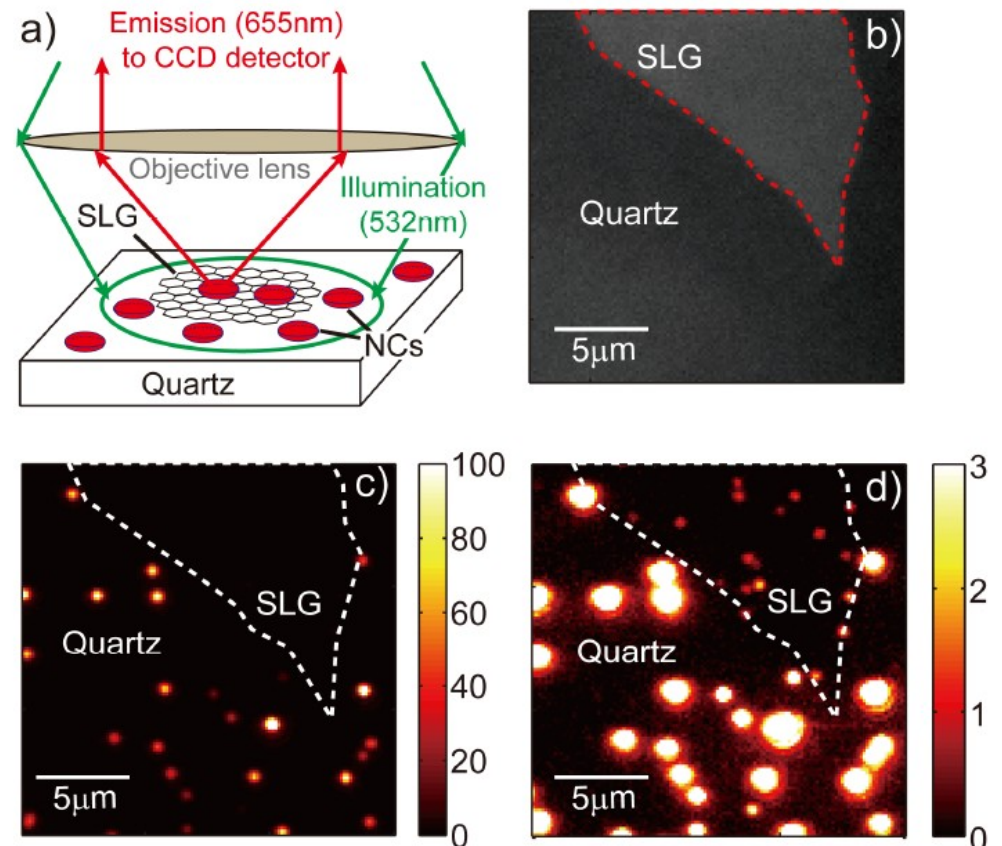

Luminescence spectroscopy:  
Z. Chen, S. Berciaud, C. Nuckols, T.F. Heinz,  
L.E. Brus, ACS Nano, 4, 2964 (2010).

# ETSFG Publications

- A. Allard and L. Wirtz, « Graphene on Metallic Substrates: Suppression of the Kohn Anomalies in the Phonon Dispersion », *Nano Lett.* **10**, 4335 (2010).
- W. Plank, R. Pfeiffer, C. Scharman, L. Wirtz, M. Calvaresi, F. Zerbetto, J. Meyer, and H. Kuzmany, « Electronic structure and radial breathing mode for carbon nanotubes with ultra-high curvature », *phys. stat. sol. (b)* **247**, 2774 (2010)
- S. Galambosi, L. Wirtz, J.A. Soininen, J. Serrano, A. Marini, K. Watanabe, T. Taniguchi, S. Huotari, A. Rubio, and K. Hämäläinen, « Anisotropic energy loss function in hexagonal boron nitride », *Phys. Rev. B* **83**, 081413(R) (2011).
- C. Attaccalite, M. Bockstedte, A. Marini, A. Rubio, and L. Wirtz, « Coupling of excitons and defect states in boron-nitride nanostructures », *Phys. Rev. B* **83**, 144115 (2011).
- A. Molina-Sánchez and L. Wirtz, « Phonons in single-layer and few-layer MoS<sub>2</sub> and WS<sub>2</sub> », *Phys. Rev. B* **84**, 155413 (2011).
- A. Molina-Sánchez and Ludger Wirtz, Ab-initio study of the excitonic effects on the optical spectra of single-layer, double-layer, and bulk MoS<sub>2</sub>, submitted to *Physical Review B* (2012).
- F. Fromm, M. H. Oliveira Jr., A. Molina-Sánchez, M. Hundhausen, J. M. J. Lopes, H. Riechert, L. Wirtz, and Th. Seyller, « The contribution of the buffer layer to the Raman spectrum of epitaxial graphene on SiC(0001) », submitted to *Nano Lett.* (2012).
- F. Forster, A. Molina-Sánchez, S. Engels, A. Epping, K. Watanabe, T. Taniguchi, L. Wirtz, and C. Stampfer, Confocal Raman spectroscopy of graphene on hexagonal boron nitride, submitted to *Nano Letters* (2012).
- J.C. Chacon-Torres, L. Wirtz, T. Pichler, Intrinsic Raman response of strained graphene layers in Graphite Intercalation Compounds, in preparation (2012).